



The QKB keyboard controllers are designed with special features to be the perfect companion for your modular synthesizer. This is not your typical store-bought keyboard, but the core of a completely modular controller system that matches the flexibility, expandability and quality of our synthesizer systems.

Available in 3-octave (37-key) and 5-octave (61-key) configurations utilizing a high-quality Fatar semi-weighted keybed, a rugged metal frame and solid wooden sides.

Removable shelves on the back and a standardized hole-pattern provide mounting points for additional modules and controllers including wheels, ribbons and whammy bars.

The MIDI interface provides a host of valuable features including velocity for both On and Off, programmable splits, and channel pressure. Two channels of merged MIDI input allow daisy-chaining to other keyboards and controllers. Power is also daisy-chainable.

Using MIDI as the primary keyboard output offers the greatest flexibility and number of options for users of our current products, and for future products. These options and flexibility are at the heart of our modular philosophy. The QKB keyboard takes the idea of modularity to controllers to give you the most choices possible.

QKB Keyboard Controller Specifications

Power Requirement: +5V@50ma

DC Power In/Out: 6-pin Female

MIDI In/Out: Standard 5-pin MIDI DIN Female

Depth from key-tip to back of shelf: 9.1"

Depth of Side: 10.9"

Height from top of black key to bottom of foot: 3.25"

QKB37 Width including sides: 22"

QKB61 Width including sides: 35"

QKB37 Weight including sides: 8#

QKB61 Weight including sides: 12#

Feature Overview

Keybed

These are not your typical economy, mass-produced, light-weight keybeds found on most modern keyboard controllers - these are quality Fatar units with semi-weighted diving-board style keys providing a solid feel, quick response and professional durability.

Enclosure

The all-metal enclosure is very rugged and capped with solid walnut side panels. The QKB-series keyboards provide our standard mounting-hole pattern (6-32 tapped holes 3.25" center-to-center) on the front and a series of removable shelves in the back. These holes provide mounting points for surface-mounted controllers such as a ribbon controller. Shelves on the back have the same mounting-holes and can be replaced with a Box1 Cabinet to house a controller module such as a Wheel, Expression Block or Whammy Bar. Single and Dual keyboard side panels are available. 61-key keyboard controllers will fit in our Studio Garage, even with a Box4 Cabinet attached and even when stacked with dual-keyboard sides.

MIDI

The internal QKB scanning circuitry produces full polyphonic MIDI note On/Off messages along with Velocity On and Velocity Off messages (a little-known and typically ignored part of the MIDI specification). Two MIDI inputs are provided which are merged with the keyboard messages then sent to the MIDI output. This allows additional controllers and keyboards to use one MIDI cable. This MIDI signal can then be patched to a Q174 MIDI Interface Module to produce one or two channels of Pitch and Gate voltages from keyboards, or voltages from other types of controllers.

Splits

The keyboard can be programmed to split into 1, 2, 3 or 4 sections that act as different keyboards, typically with separate MIDI channels. Two MIDI signals can be decoded by a Q174 MIDI interface to produce two separate Pitch/Gate signals. This second channel of pitch voltages can be used to transpose the first using the Q174's Add Input, or simply used as a second channel for another synthesizer voice. Splits, MIDI channel number, velocity curves, transposing and other features are programmed through special key sequences or via MIDI NRPN messages.

Pressure

QKB keyboard controllers provide a Channel Pressure signal (sometimes erroneously called Aftertouch). Channel pressure is produced when applying pressure to a key at the bottom of travel. There is one Channel Pressure signal for the entire keyboard. The Q174 MIDI interface module produces a voltage from this signal which can then be used for pitch bending, changing filter parameters, amplitude control, or any other synthesizer parameter. Pressure is sent using the MIDI channel number for Split #1.

Power

The QKB uses our standard DC power connector to connect to our QPS4 or QPS5 power supplies, or to share power from a synthesizer cabinet via a QIC cable. If you do not have a synthesizer system or a source for power, use the QPS4 power supply. A power output connector is also provided to daisy-chain the power to additional keyboards, or controllers mounted in Box cabinets.

QKB37 Keyboard with Box4 and controllers



Dual keyboard brackets with a Box4 cabinet



Power

The keyboard controller receives power from our standard 6-pin circular DIN connector that provides +15V, -15V, +5V and ground.

Power can be provided by a QPS4 power supply, a QPS5 power supply or via a QIC cable from a system.

There are two power connectors. One is used as a power input, the other as an output to send power to additional controllers or a cabinet containing synthesizer modules. Be mindful of the power consumption. Overloading a power source typically results in one of the power rails turning off.

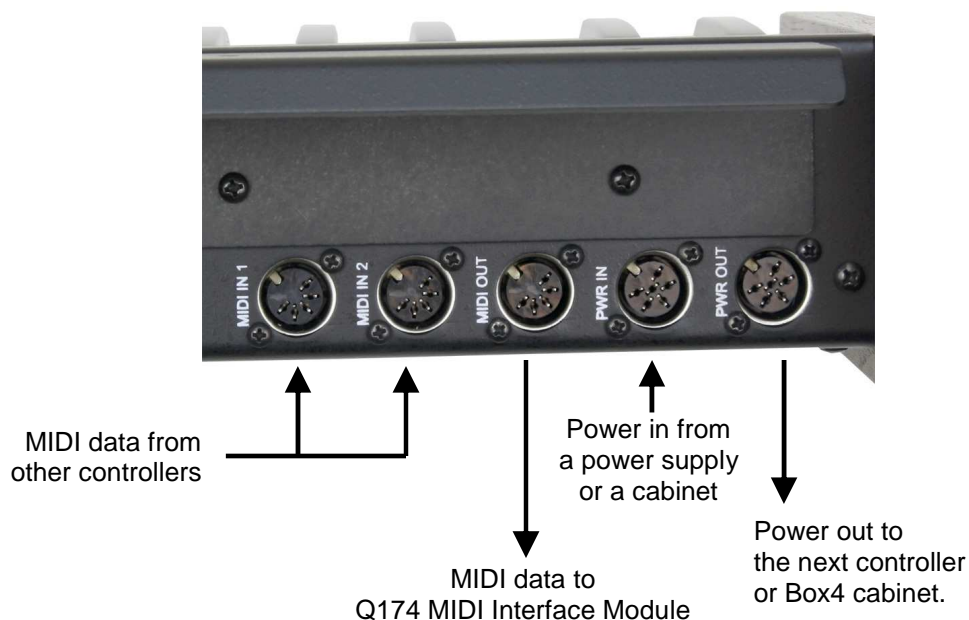

MIDI Merging

Along with a MIDI output port which sends MIDI data from the keyboard, two MIDI inputs are provided. MIDI data from these inputs are merged inside the controller and sent to the MIDI output along with the keyboard data.

Merging allows multiple keyboards to share a common MIDI cable, and allows other MIDI controller information to be merged together.

For example, a second keyboard controller set to MIDI channel #2 could be connected to one of the MIDI merge inputs then one cable from the MIDI output patched to a Q174 MIDI Interface Module. The Q174 has an setting to produce two groups of pitch and gate outputs from two separate MIDI channels.

MIDI data speed may be a limiting factor when merging several busy MIDI data streams.

Power and MIDI Connection Examples

Here's a simple setup with a power supply, keyboard controller, and a Q174 MIDI Interface Module mounted in a synthesizer cabinet. The Q174 generates Pitch and Gate signals from the MIDI data.

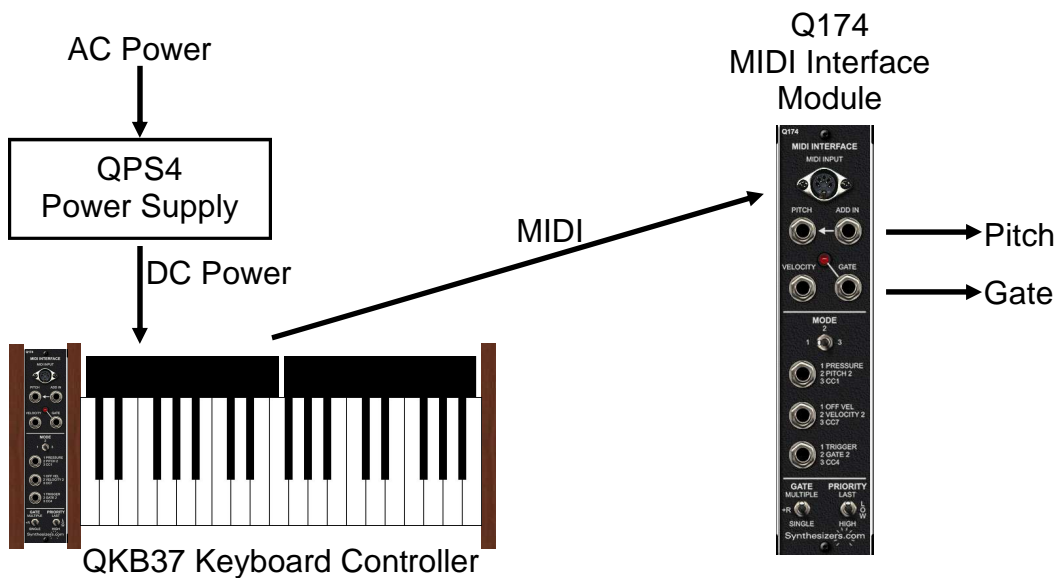

This example shows a typical keyboard controller and a Box2 cabinet housing two modules. Power to the keyboard controller comes from the synthesizer system. Power is then daisy-chained to the Box2.

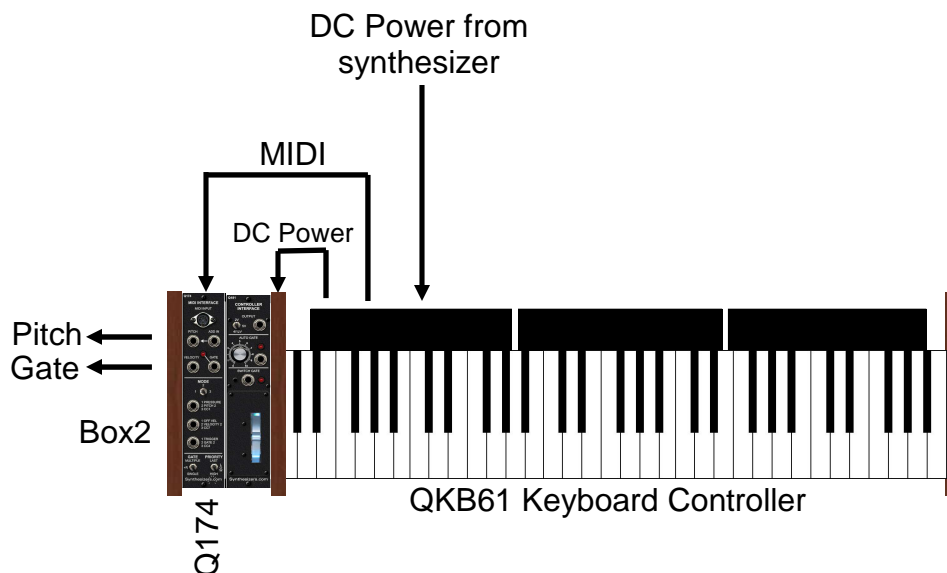

Parameters

Parameters are changed by holding the first E and F key down while turning power On.

Hold these 2 keys down during power-On to enter configuration mode



Two short MIDI notes are produced when entering configuration mode.

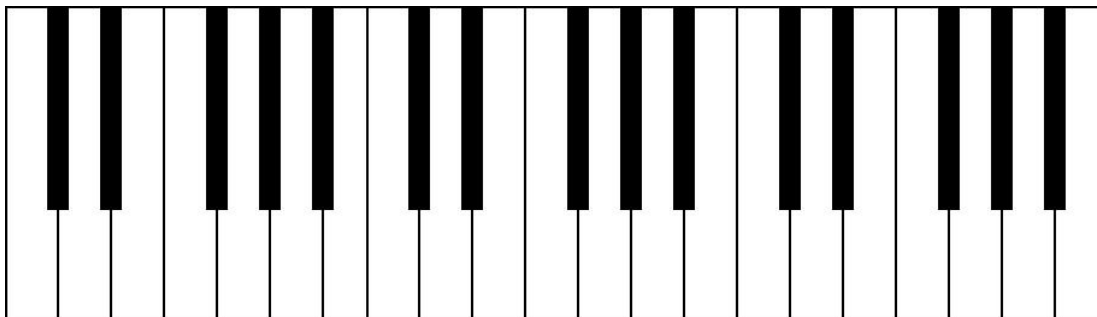

Black keys select the parameter or action



As keys are pressed, a short MIDI note is produced for feedback.

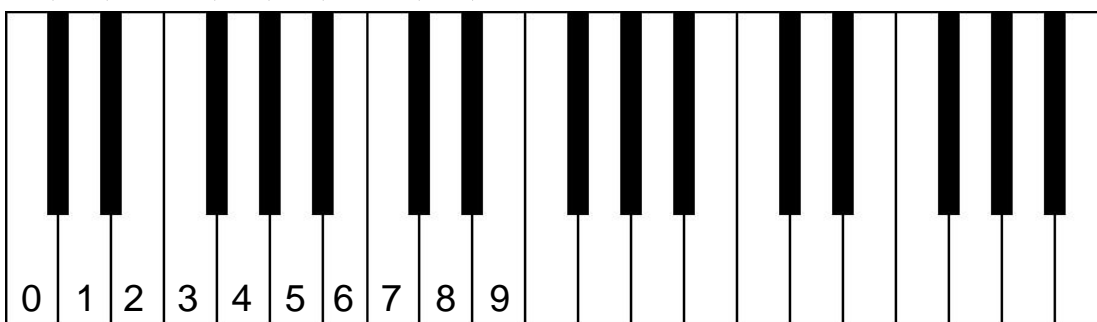

White keys represent numbers to enter values

Parameters - continued

After entering configuration mode, select the parameter by pressing a black key. Then enter parameter values using the white keys. To enter a 2-digit parameter value, enter a leading 0 if necessary to create 2 digits. After all values are entered, you may then select another parameter from the black keys, or press *Save and Exit* and return to playing with the new parameter settings. Refer to the chart for key values.

Save and Exit

Saves the new parameters and returns to normal keyboard playing.

Set Factory Defaults

Sets the factory default of 1 keyboard split, MIDI channel 1, transposed to 36, Velocity curve exponential, Pressure curve exponential. The defaults are saved and the keyboard returns to normal playing.

Split

The physical keyboard can be split into multiple virtual keyboards. Each split may have a unique MIDI channel number and a unique transposition. Up to 4 splits are possible. Press F# to configure a split. Then enter the split number using the white keys. Valid split numbers are 1,2,3 or 4. Then enter a 2-digit start key number. Keys are numbered 0 through the end of the keyboard. The end key on the far right of a 37-key keyboard is #36, and #60 on a 61-key keyboard. Then enter a 2-digit key count which sets the number of keys in the split.

MIDI Channel

Each split has its own MIDI channel number. After pressing the G# key to change the MIDI channel, enter the split #. Valid split numbers are 1,2,3 or 4. Then enter a 2-digit MIDI channel number. Valid MIDI channel numbers are 01-16.

Transpose

Each split has its own transposition to shift the keys up or down the scale. A typical transpose number would be 36, meaning the first key in the split would be MIDI note #36 which is 2 octaves below middle C. A transposition of 36 allows the Q174 MIDI Interface to operate a Q106 Oscillator in its complete range. Press the A# key to change transpose, then enter a split number 1,2,3 or 4. Then enter a 2-digit transpose value for that split.

Velocity Curve

The velocity curve determines the relationship between the key-press speed and the MIDI velocity output value. It affects how the velocity output responds to your style of playing. The velocity curve applies to all keys and splits on the keyboard. Press the 2nd C# to change the velocity curve. Then enter a 2-digit curve code from the list below. 02 is the factory default. Then enter a 2-digit velocity bottom value which sets the lowest MIDI velocity value possible. Use 00 to leave the curve unchanged. See the section about velocity curves for additional details.

Pressure Curve

The pressure curve determines the relationship between the Aftertouch force and the MIDI pressure output value. The pressure curve applies to all keys and is sent using the MIDI channel for split #1. Press the 2nd D# to change the curve type. Now enter the 2-digit curve code from the list below. 02 is the factory default. Within 5 seconds after that, press any key on the keyboard very hard to calibrate the pressure. You will then hear a beep indicating the calibration routine is complete.

Curve Codes

0=Linear, 1=Exponential1, 2=Exponential2, 3=Log1, 4=Log2, 5=S, 6=N, 7=Random, 8=Quantized, 9=Fixed to 1, 10=Fixed to 32, 11=Fixed to 64, 12=Fixed to 96, 13=Fixed to 127.

Keyboard Splits

The physical keyboard can be split into multiple virtual keyboards. This can be useful for playing bass lines on the left and lead on the right, or for using the output of one-octave to transpose the others. Four splits are possible, each with its own MIDI channel number and transposition.

The factory default is 1 split for the entire keyboard, MIDI channel 1, and a transposition of 36 (3 octaves).

Factory default, 1 split

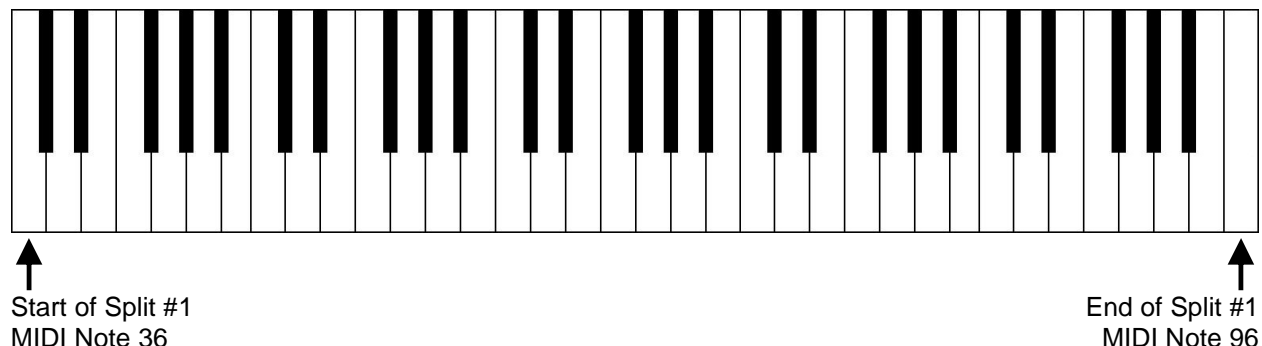

Two Split Example on a 61-Key Keyboard

This creates a 2-octave keyboard and a 3-octave keyboard

Start configuration mode by holding the first E and F key during power-On.

Press F# to set the first split.

Choose Split 1 by pressing D.

Enter 00 for the start key by pressing C then C.

Enter 24 for the split key count by pressing E then G. The first split is now set.

Press F# to set the second split.

Choose Split 2 by pressing E.

Enter 24 for the start key by pressing E then G.

Enter 37 for the split key count by pressing F then C. The second split is now set.

Save and Exit by pressing C#.

You can also set the MIDI channel number and transposition for each split.

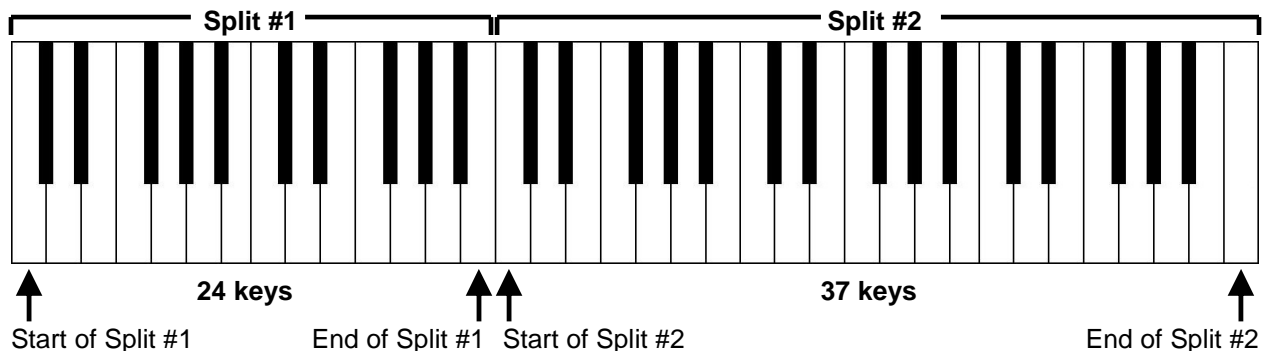

Four Split Example on a 61-Key Keyboard

Start configuration mode by holding the first E and F key during power-On.

Press F# to set a split.

Enter 1 for the Split number by pressing D.

Enter 00 for the start key by pressing C then C.

Enter 12 for the split key count by pressing D then E. Split #1 is now set.

Press G# to set the channel number.

Enter 1 for the Split number by pressing D.

Enter 01 for the channel number by pressing C then D. Split #1 channel number is now set

Press F# to set a split.

Enter 2 for the Split number by pressing E.

Enter 12 for the start key by pressing D then E.

Enter 12 for the split key count by pressing D then E. Split #2 is now set.

Press G# to set the channel number.

Enter 2 for the Split number by pressing E.

Enter 02 for the channel number by pressing C then E. Split #2 channel number is now set

Press F# to set a split.

Enter 3 for the Split number by pressing F.

Enter 24 for the start key by pressing E then G.

Enter 12 for the split key count by pressing D then E. Split #3 is now set.

Press G# to set the channel number.

Enter 3 for the Split number by pressing F.

Enter 03 for the channel number by pressing C then F. Split #3 channel number is now set

Press F# to set a split.

Enter 4 for the Split number by pressing G.

Enter 36 for the start key by pressing F then B.

Enter 25 for the split key count by pressing E then A. Split #4 is now set.

Press G# to set the channel number.

Enter 4 for the Split number by pressing G.

Enter 08 for the channel number by pressing C then D2. Split #4 channel number is now set

Save and Exit by pressing C#.

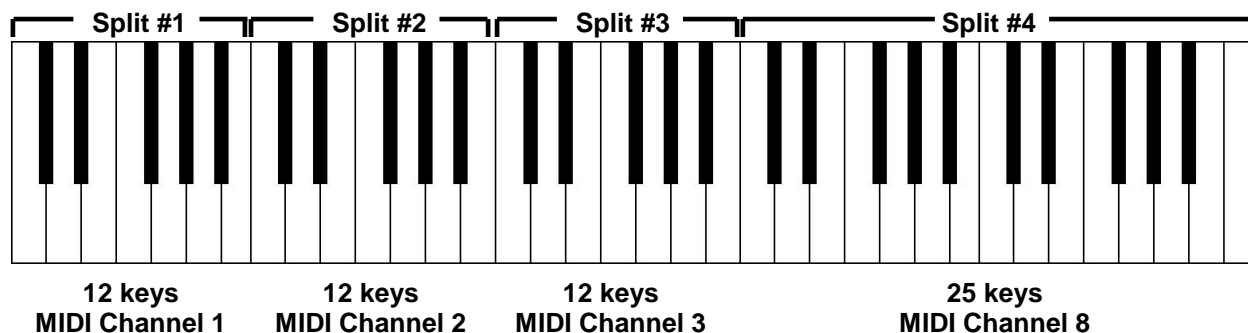

Velocity Curves

Velocity curve is the relationship between the speed at which you press a key and the MIDI velocity value sent out. Changing this relationship changes the key response. What feels best and allows the most expressive playing experience depends upon your playing style and habits. The best way to determine the ideal velocity curve is to try them all, but most will find Exponential 2 produces the best results, and that's the factory default.

When selecting a velocity curve, you'll need to enter a velocity curve code - 0=Linear, 1=Exponential1, 2=Exponential2, 3=Log1, 4=Log2, 5=S, 6=N, 7=Random, 8=Quantized, 9=Fixed to 1, 10=Fixed to 32, 11=Fixed to 64, 12=Fixed to 96, 13=Fixed to 127.

In addition to a curve code, you'll need to provide a Bottom value 00-99. This Bottom value modifies the curve and sets the lowest possible velocity value. A Bottom value of 00 leaves the curve unchanged.

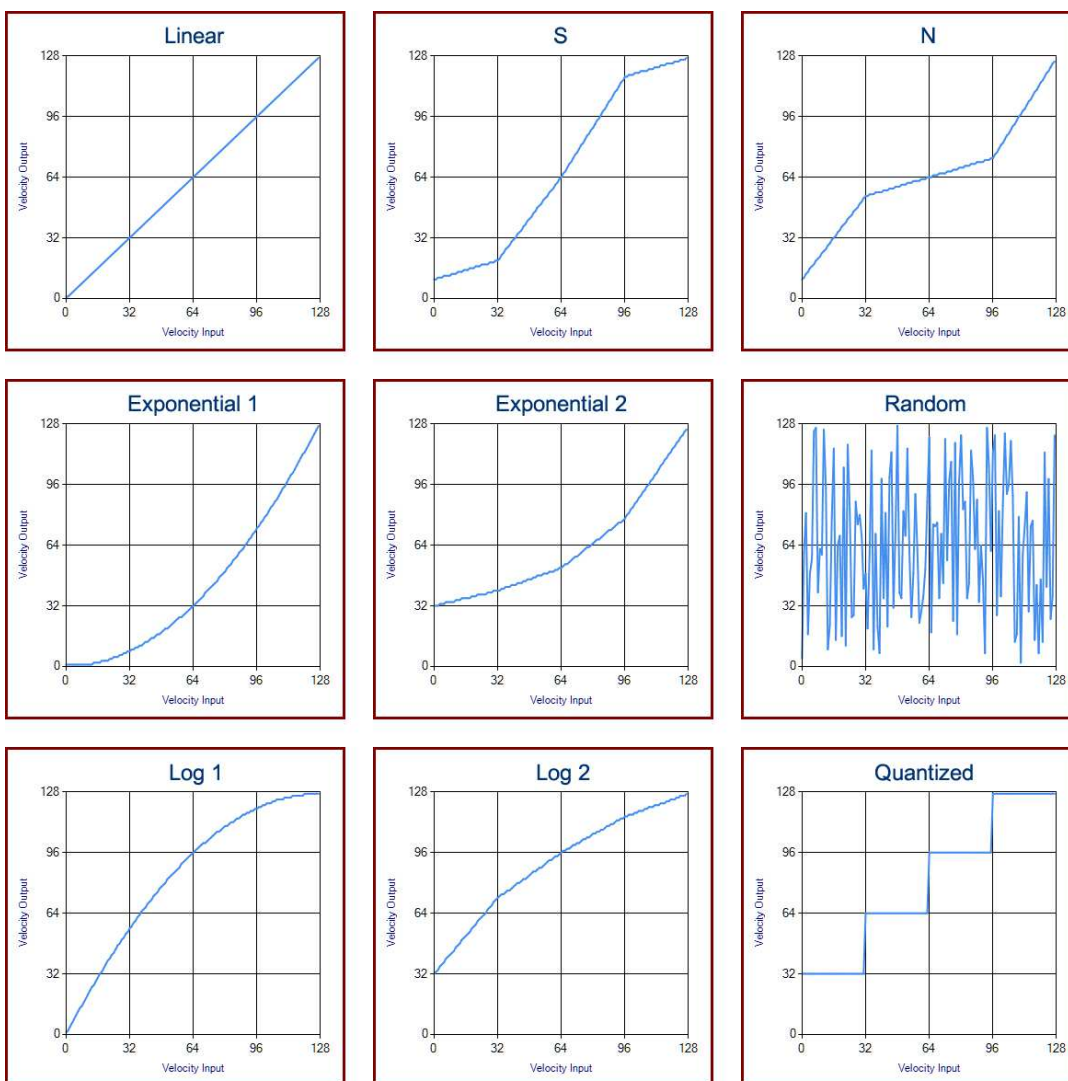

Changing Parameters using MIDI

Parameters can be changed using the power-on configuration sequence, or by sending MIDI data through MIDI Input #1. This allows computers and other devices capable of sending MIDI to control parameters of the keyboard.

Parameter changes occur on MIDI port #1 and MIDI channel 16. NRPN (Non-Registered Parameter Numbers) are used to select the parameter and value. Other MIDI data coming into MIDI port #1 is simply merged into the MIDI output stream.

To set a parameter, first send an NRPN LSB (CC98) with the parameter number shown below, then send an NRPN MSB (CC99) with 0, then send the value using CC6. For example, to change the Velocity curve to 2, send:

CC98 on MIDI channel 16 with a value of 50,
CC99 on MIDI channel 16 with a value of 0,
CC6 on MIDI channel 16 with a value of 2,

NRPN	Parameter
10	Keyboard Split #1 - Start Key
11	Keyboard Split #1 - Key Count
12	Keyboard Split #1 - Transpose
13	Keyboard Split #1 - MIDI Channel
20	Keyboard Split #2 - Start Key
21	Keyboard Split #2 - Key Count
22	Keyboard Split #2 - Transpose
23	Keyboard Split #2 - MIDI Channel
30	Keyboard Split #2 - Start Key
31	Keyboard Split #2 - Key Count
32	Keyboard Split #2 - Transpose
33	Keyboard Split #2 - MIDI Channel
40	Keyboard Split #3 - Start Key
41	Keyboard Split #3 - Key Count
42	Keyboard Split #3 - Transpose
43	Keyboard Split #3 - MIDI Channel
50	Velocity Curve Type Code
51	Velocity Curve Bottom Value
60	Pressure Curve Type Code
62	Pressure High Value
80	Set factory Defaults
81	Save Current Settings

Mounting Holes

Standardized mounting holes are provided for surface-mountable controllers such as ribbons and thumb buttons. The holes can be found on the removable shelves on the back of the keyboard and on the front of the keyboard under the keys. These holes are 6-32 threads, 3.25" center-to-center.



Circuit Board Connector Layout

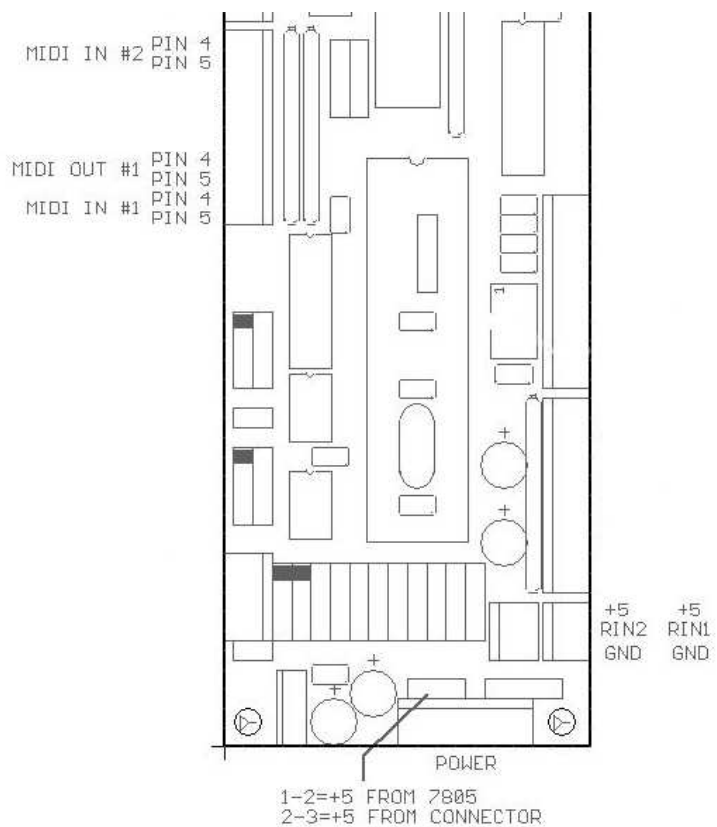

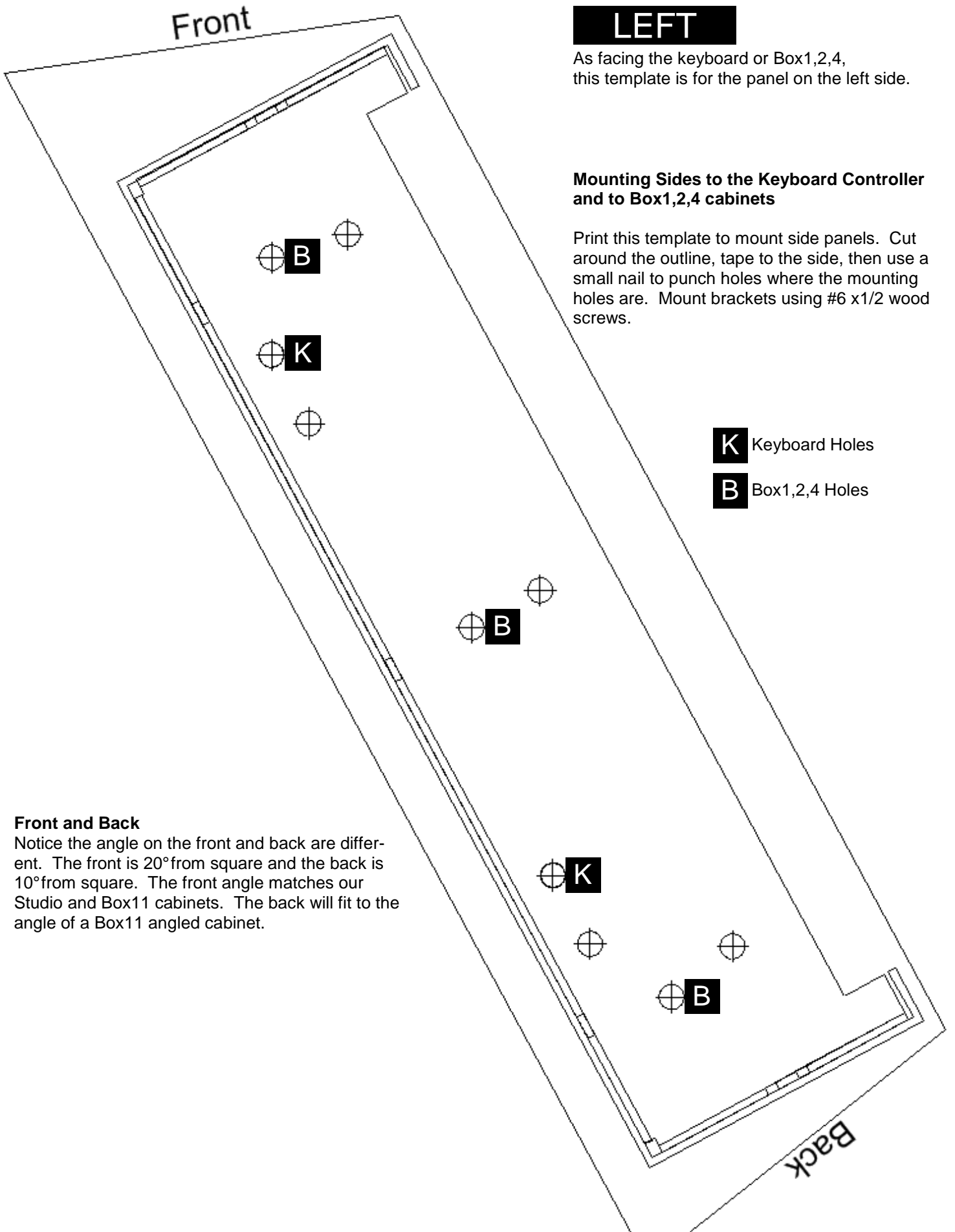

LEFT

As facing the keyboard or Box1,2,4, this template is for the panel on the left side.

Mounting Sides to the Keyboard Controller and to Box1,2,4 cabinets

Print this template to mount side panels. Cut around the outline, tape to the side, then use a small nail to punch holes where the mounting holes are. Mount brackets using #6 x1/2 wood screws.

- K** Keyboard Holes
- B** Box1,2,4 Holes

Front and Back

Notice the angle on the front and back are different. The front is 20° from square and the back is 10° from square. The front angle matches our Studio and Box11 cabinets. The back will fit to the angle of a Box11 angled cabinet.

This page is mostly blank

RIGHT

As facing the keyboard or Box1,2,4, this template is for the panel on the right side.

Mounting Sides to the Keyboard Controller and to Box1,2,4 cabinets

Print this template to mount side panels. Cut around the outline, tape to the side, then use a small nail to punch holes where the mounting holes are. Mount brackets using #6 x1/2 wood screws.

B Box1,2,4 Holes

K Keyboard Holes

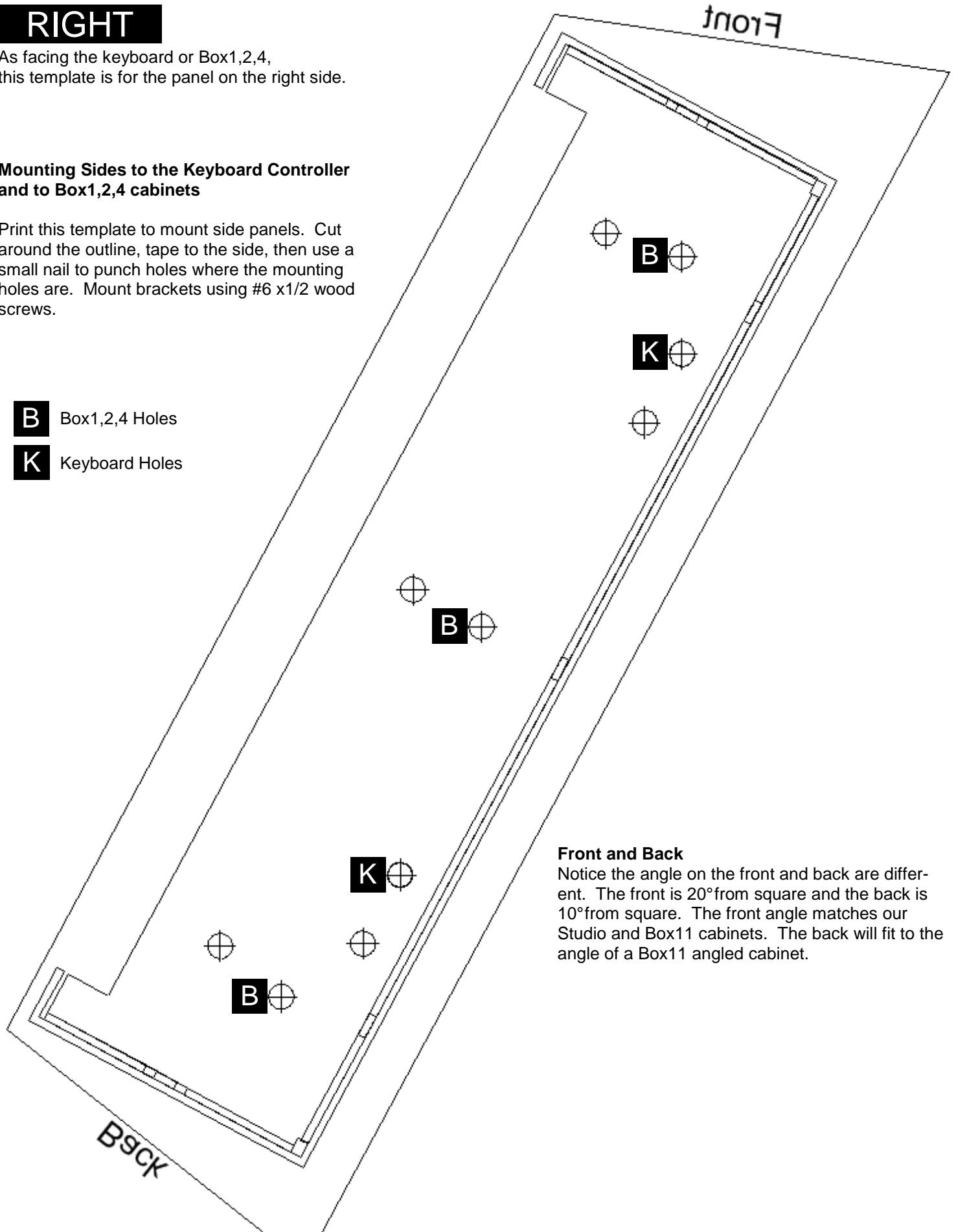

Front and Back

Notice the angle on the front and back are different. The front is 20° from square and the back is 10° from square. The front angle matches our Studio and Box11 cabinets. The back will fit to the angle of a Box11 angled cabinet.

This page is mostly blank

Save	Defaults	Splits	Channel	Trans	Velocity	Pressure			
0	1	2	3	4	5	6	7	8	9

Keyboard template for configuration mode

Print and cut.

← C on far left of keyboard